

# R RotoPack<sup>®</sup>

PACKAGING MACHINES

MADE IN ITALY  
SINCE 1994



## FUTURA

TERMOSIGILLATRICE AUTOMATICA

VUOTO-GAS

AUTOMATIC THERMOSEALER

WITH VACUUM AND GAS



**ROTOPACK SRL**

Via Carbonari, 16 - 20030 PADERNO DUGNANO (MI - ITALY) - Tel. +39.02.99044396 - Fax +39.02.99042582

info@rotopacksrl.com - www.rotopacksrl.com

## Caratteristiche tecniche

- ✓ Termosigillatrice automatica per confezionamento sottovuoto e in ATM di vaschette preformate in PP, PE, PS, PET, AL ecc.
- ✓ Piastra saldante teflonata
- ✓ Taglio film attorno al bordo della vaschetta con possibilità di ricavare linguetta per l'apertura facilitata del contenitore
- ✓ Stampi realizzati su misura per qualsiasi forma
- ✓ Touch screen con 10 programmi memorizzabili
- ✓ Controllo della temperatura tramite termoregolatore e sonda PT 100
- ✓ Funzioni extra vuoto e extra gas
- ✓ Cambio stampo rapido
- ✓ Sensore di pressione vuoto/gas

### Optional

- ✓ Versione "solo saldatura"
- ✓ Pompa fomblinizzata per miscele di gas con alta % di ossigeno
- ✓ Fotocellula per la centratura di film stampato
- ✓ Disimpilatore vaschette
- ✓ Sistemi di dosaggio

## Technical features

- ✓ Automatic vacuum/MAP sealing machine for performed trays in PP, PE, PS, PET, AL etc.
- ✓ Teflon coated sealing plate
- ✓ Profile cutting to the tray size with possibility to create an easy peel angle to facilitate the tray opening
- ✓ Moulds made on tray samples for any shape
- ✓ Touch screen with 10 storable programs
- ✓ Digital temperature controller with PT 100 probe
- ✓ Extra vacuum and extra gas functions
- ✓ Fast tool change
- ✓ Pressure sensor for vacuum and gas

### Optional

- ✓ Version "only sealing"
- ✓ Special vacuum pump for gas mixtures with high oxygen%
- ✓ Photocell for printed film
- ✓ Tray denester
- ✓ Filling systems

## Caractéristiques techniques

- ✓ Operculeuse automatique vide et gaz de barquettes en PP, PE, PS, PET, AL etc.
- ✓ Plaque de soudage téflonisée
- ✓ Découpe du film autour de la barquette avec possibilité de découper une languette pour l'ouverture facilitée des barquettes
- ✓ Moules sur mesure pour toutes les formes
- ✓ 10 programmes mémorisables
- ✓ Contrôle de la température par thermostat et sonde PT 100
- ✓ Fonctions extra vide et extra gaz
- ✓ Changement rapide d'outillage
- ✓ Capteur de pression pour vide et gaz

### Optionnel

- ✓ Version "seulement soudage"
- ✓ Pompe spéciale pour mélanges de gaz avec élevée % d'oxygène
- ✓ Cellule pour le centrage de film imprimé
- ✓ Dépilleur de barquettes
- ✓ Systèmes de dosage

## Technische Merkmale

- ✓ Automatische Schalenriegelmaschine für Vakuumverpackung in modifizierter Atmosphäre für Schalen aus PP, PE, PS, PET, AL usw.
- ✓ Teflonbeschichtete Siegelplatte
- ✓ Abschneiden der Folie am Schalenrand mit Lasche für ein einfacheres Öffnen des Behälters
- ✓ Nach Maß angefertigte Formen für beliebige Formate
- ✓ Touch Screen mit 10 speicherbare Programme
- ✓ Temperaturkontrolle über Thermostat und Pt100 Sonde
- ✓ Extra Vakuum und extra Gas Funktion
- ✓ Schnellwechseleinrichtung
- ✓ Drucksensor Vakuum und Gas

### Sonderzubehör

- ✓ Ausführung nur Schweißen
- ✓ Sauerstoffpumpe
- ✓ Fotozelle für Zentrierung der bedruckten Folie
- ✓ Schalenentstapler
- ✓ Dosierungsanlage

# FUTURA

## TERMO SIGILLATRICE AUTOMATICA VUOTO-GAS

### AUTOMATIC THERMOSEALER WITH VACUUM AND GAS

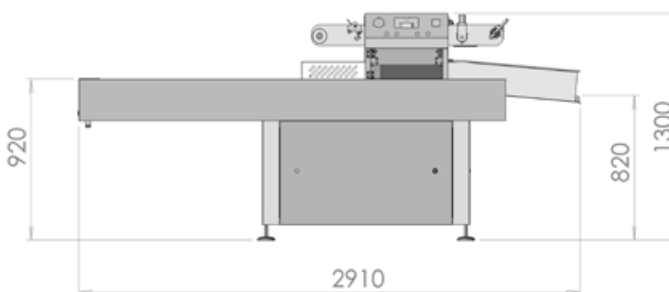
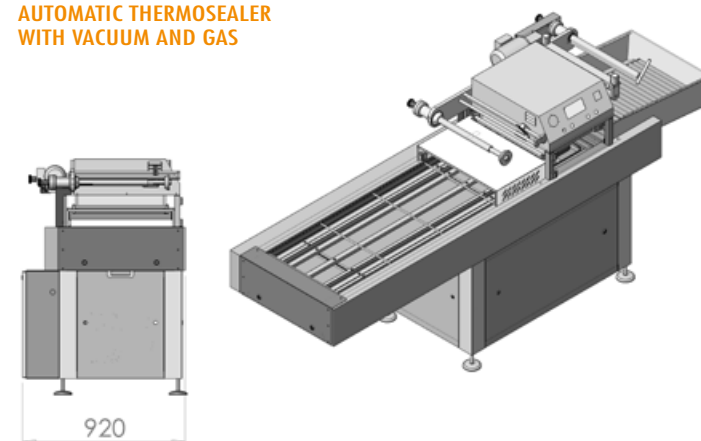

430mm x 290mm

290mm x 205mm

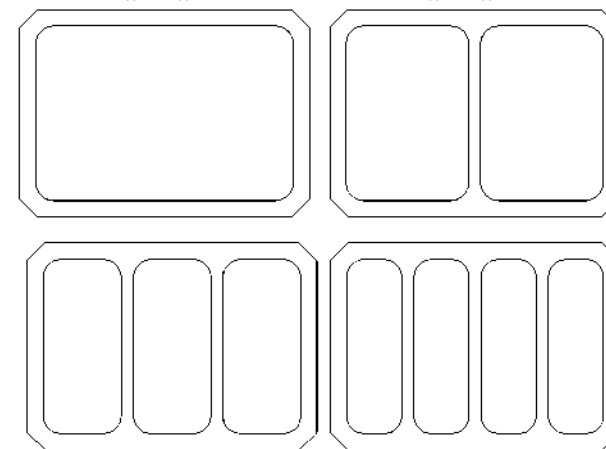

290mm x 130mm

290mm x 93mm

Tensione	Power	Puissance	Spannung	400 V. - 50/60 HZ 3P+N+PE
Potenza assorbita	Power consumption	Consommation	Leistungsaufnahme	5,2 KW
Aria compressa	Air supply	Consommation pneumatique	Druckluft	20 NL/ciclo
Pressione	Air pressure	Pression aire	Druck	6 bar
Peso	Weight	Poids	Gewicht	Kg. 500
Max dimensione contenitori	Max. Container dimensions	Max. Dimensions pots	Max. Abmessungen behälter	mm. 430 x 290 x h. 100
Dimensioni macchina	Machine dimensions	Dimensions de la machine	Abmessungen dermaschine	mm. 2910 x 920 x h. 1300
Pompa vuoto	Vacuum pump	Pompe a vide	Vakuumpumpe	105 m3
Fascia film	Max. Film width	Max. Laize du film	Max. Breite der folie	mm. 500
Produttività vuoto-gas/saldatura	Productivity vac-gas /only sealing	Productivite' vide-gas/scellage	Produktivität vakuum-gas/nur siegelung	5/12 cicli/min