

R RotoPack®

PACKAGING MACHINES



MADE IN ITALY
SINCE 1994

RAPIDA
TERMOSIGILLATRICE
SEMI AUTOMATICA
SEMI AUTOMATIC
THERMOSEALER



ROTOPACK SRL

Via Carbonari, 16 - 20030 PADERNO DUGNANO (MI - ITALY) - Tel. +39.02.99044396 - Fax +39.02.99042582

info@rotopacksrl.com - www.rotopacksrl.com

Caratteristiche tecniche

- ✓ Termosigillatrice semiautomatica per vaschette preformate in PP, PE, PS, PET, AL ecc.
- ✓ Piastra saldante teflonata
- ✓ Taglio film attorno al bordo della vaschetta con possibilità di ricavare linguetta per l'apertura facilitata del contenitore
- ✓ Controllo della temperatura tramite termoregolatore e sonda PT 100
- ✓ Tempo di saldatura regolabile
- ✓ Struttura in acciaio inox, alluminio e polizene
- ✓ Stampi realizzati su misura per qualsiasi forma

Optional

- ✓ Versione "Rapida plus" con cambio stampo rapido
- ✓ Stampi speciali per sigillare coperchi pretagliati

Technical features

- ✓ Semi automatic sealing machine for preformed trays in PP, PE, PS, PET, AL etc.
- ✓ Teflon coated sealing plate
- ✓ Profile cutting to the tray size with possibility to create an easy peel angle to facilitate the tray opening
- ✓ Digital temperature controller with PT 100 probe
- ✓ Adjustable sealing time
- ✓ Structure in stainless steel, aluminium and polythene
- ✓ Moulds made on tray samples for any shape

Optional

- ✓ Model "Rapida plus" with fast tool change
- ✓ Special moulds to seal pre-cut lids

Caractéristiques techniques

- ✓ Operculeuse semi automatique de barquettes en PP, PE, PS, PET, AL etc.
- ✓ Plaque de soudage téflonisée
- ✓ Découpe du film autour de la barquette avec possibilité de découper une languette pour l'ouverture facilitée des barquettes
- ✓ Contrôle de la température par thermorégulateur et sonde PT 100
- ✓ Temps de soudure réglable
- ✓ Structure en acier inox, aluminium et polyéthylène
- ✓ Moules sur mesure pour toutes les formes

Optionnel

- ✓ Modèle "Rapida plus" avec système de changement moule rapide
- ✓ Moule spécial pour le soudage de opercules pré-coupés

Technische Merkmale

- ✓ Halbautomatische Siegelmaschine für vorgeformte Schalen aus PP, PE, PS, PET, AL usw.
- ✓ Teflonbeschichtete Siegelplatte
- ✓ Abschneiden der Folie am Schalenrand mit Lasche für ein einfacheres Öffnen des Behälters
- ✓ Temperaturkontrolle über Thermostat und Pt100 Sonde
- ✓ Einstellbare Siegelzeit
- ✓ Struktur aus Edelstahl, Aluminium und Polyzen
- ✓ Nach Maß angefertigte Formen für beliebige Formate

Sonderzubehör

- ✓ Version "rapida plus" mit schnellem Formenwechsel
- ✓ Spezialform für die Versiegelung vorgeschnittener Deckel

Tensione	Power	Puissance	Spannung	230V - 50/60 Hz - P + N + PE
Potenza assorbita	Power consumption	Consommation	Leistungsaufnahme	2 KW
Aria compressa	Air supply	Consommation pneumatique	Druckluft	1,4 NL/ciclo
Pressione	Air pressure	Pression aire	Druck	6 bar
Peso	Weight	Poids	Gewicht	55 Kg.
Max dimensione contenitori	Max. Container dimensions	Max. Dimensions pots	Max. Abmessungen behälter	mm. 350 x 270 x h.150
Dimensioni macchina	Machine dimensions	Dimensions de la machine	Abmessungen dermaschine	mm. 585 x 730 x 450
Fascia film	Max. Film width	Max. Laize du film	Max. Breite der folie	mm. 400

RAPIDA

TERMOSIGILLATRICE
SEMIAUTOMATICA

SEMI AUTOMATIC
THERMOSEALER

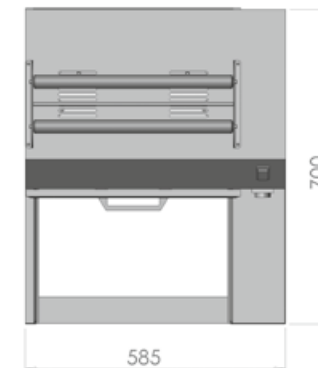
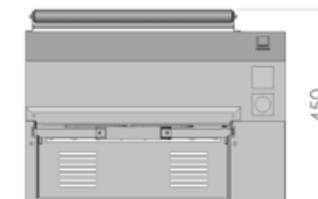
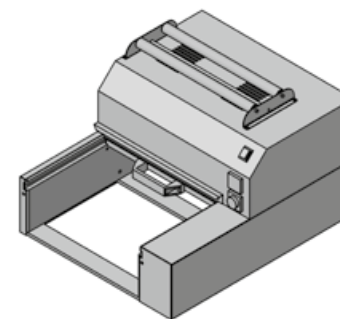

350mm × 270mm

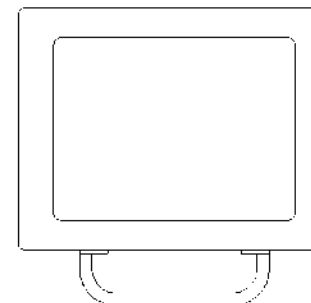

177mm × 270mm

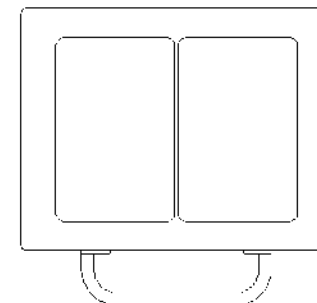

170mm × 132mm

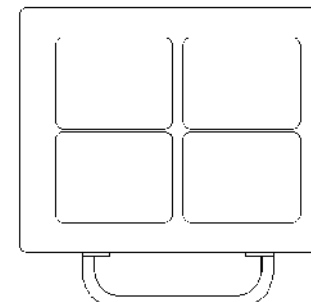

130mm × 105mm

