

# R RotoPack®

PACKAGING MACHINES

MADE IN ITALY  
SINCE 1994



**GAMMA SR**  
TERMOSIGILLATRICI MANUALI  
MANUAL THERMOSEALERS

**ROTOPACK SRL**

Via Carbonari, 16 - 20030 PADERNO DUGNANO (MI - ITALY) - Tel. +39.02.99044396 - Fax +39.02.99042582

info@rotopacksrl.com - www.rotopacksrl.com

## Caratteristiche tecniche

- ✓ Termosigillatrice manuale per vaschette preformate in PP, PE, PS, PET, AL ecc.
- ✓ Piastra saldante teflonata
- ✓ Controllo della temperatura tramite termoregolatore e sonda PT 100
- ✓ Struttura in acciaio inox, alluminio e polizene
- ✓ Stampi realizzati su misura per qualsiasi forma

### Optional

- ✓ Taglio film attorno al bordo della vaschetta con possibilità di ricavare linguetta per l'apertura facilitata del contenitore
- ✓ Possibilità di saldare vaschette fino h. 185 mm
- ✓ Stampi speciali per sigillare coperchi pretagliati

## Technical features

- ✓ Manual sealing machine for preformed trays in PP, PE, PS, PET, AL etc.
- ✓ Teflon coated sealing plate
- ✓ Digital temperature controller with PT 100 probe
- ✓ Structure in stainless steel, aluminium and polythene
- ✓ Moulds made on tray samples for any shape

### Optional

- ✓ Profile cutting to the tray size with possibility to create an easy peel angle to facilitate the tray opening
- ✓ Possibility to seal trays up to h 185 mm.
- ✓ Special moulds to seal pre-cut lids

## Caractéristiques techniques

- ✓ Operculeuse manuelle de barquettes en PP, PE, PS, PET, AL etc.
- ✓ Plaque de soudage téflonisée
- ✓ Contrôle de la température par thermorégulateur et sonde PT 100
- ✓ Structure en acier inox, aluminium et polyéthylène
- ✓ Moules sur mesure pour toutes les formes

### Optionnel

- ✓ Découpe du film autour de la barquette avec possibilité de découper une languette pour l'ouverture facilitée des barquettes
- ✓ Possibilité de souder barquettes jusqu'à h. 185 mm.
- ✓ Moule spécial pour le soudage de opercules pré coupés

## Technische Merkmale

- ✓ Handsiegelgerät für vorgeformte Schalen aus PP, PE, PS, PET, AL usw.
- ✓ Teflonbeschichtete Siegelplatte
- ✓ Temperaturkontrolle über Thermostat und Pt100 Sonde
- ✓ Struktur aus Edelstahl, Aluminium und Polyzen
- ✓ Nach Maß angefertigte Formen für beliebige Formate

### Sonderzubehör

- ✓ Abschneiden der Folie am Schalenrand mit Lasche für ein einfacheres Öffnen des Behälters
- ✓ Schweißen von Wannen bis zu 185 mm H möglich.
- ✓ Spezialform für die Versiegelung vorgeschchnittener Deckel.

				SR 230	SR 430
Tensione	Power	Puissance	Spannung	230 V. - 50/60 Hz P+N+PE	230 V. - 50/60 Hz P+N+PE
Potenza assorbita	Power consumption	Consommation	Leistungsaufnahme	1 KW	2 KW
Peso	Weight	Poids	Gewicht	Kg. 25	Kg. 35
Max dimensione contenitori	Max. Container dimensions	Max. Dimensions pots	Max. Abmessungen behälter	mm.190 x 200 h. 95	mm. 390 x 265 x h. 120
Dimensioni macchina	Machine dimensions	Dimensions de la machine	Abmessungen dermaschine	mm.320 x 500 x 500	mm. 520 x 600 x 500
Fascia film	Max. Film width	Max. Laize du film	Max. Breite der folie	mm. 200	mm. 400

## GAMMA SR

TERMOSIGILLATRICI MANUALI  
MANUAL THERMOSEALERS

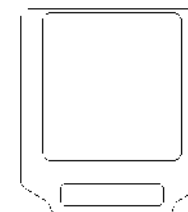
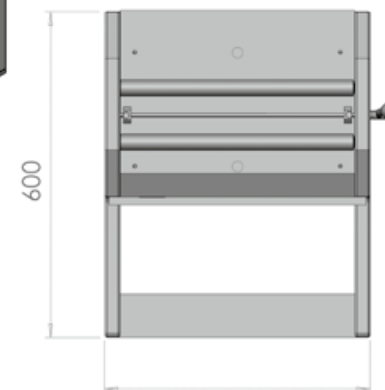
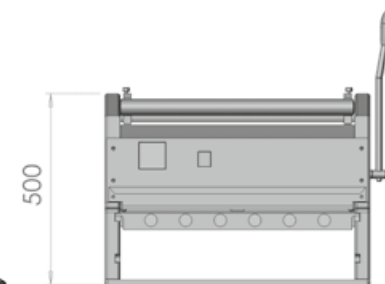
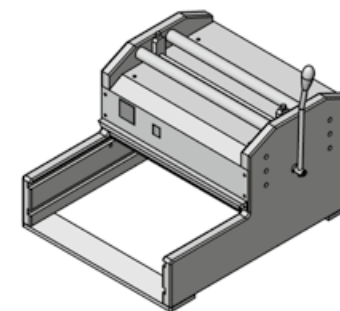

SR 230  
190mm x 200mm

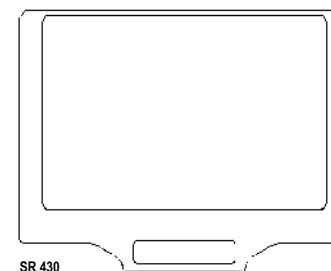

SR 430  
390mm x 265mm

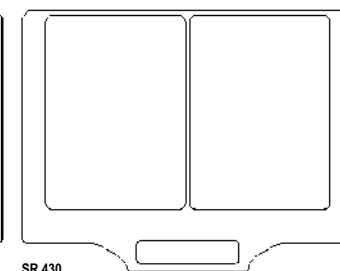

SR 430  
192mm x 265mm

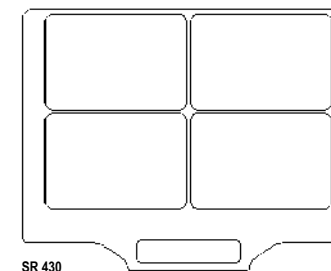

SR 430  
192mm x 130mm

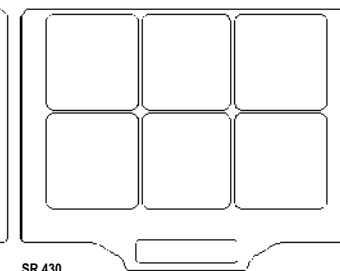

SR 430  
126mm x 130mm