

Formeuses à steak

Forming machines

F2000

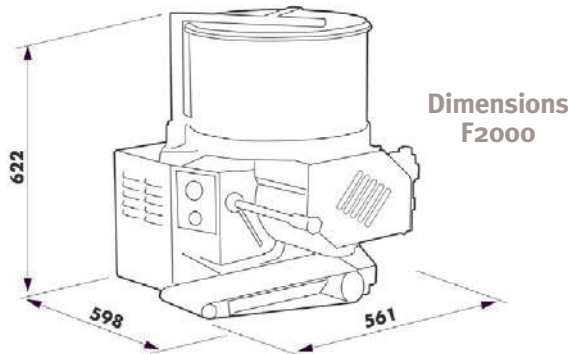

Différentes formes d'empreintes possibles
Differents forms and weights available

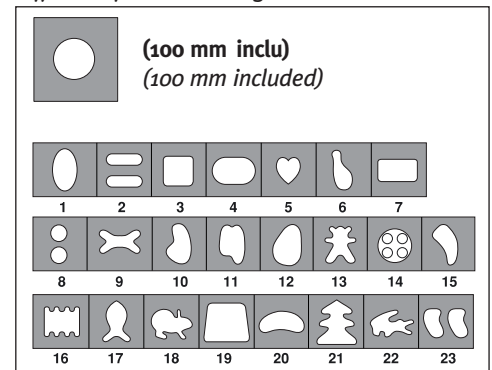

F3000

Équipée de : *Equipped in :*
Tapis long, pédale, trémie d'alimentation
et interfolieur
– *With long conveyer, pedal
and feeding hopper.*

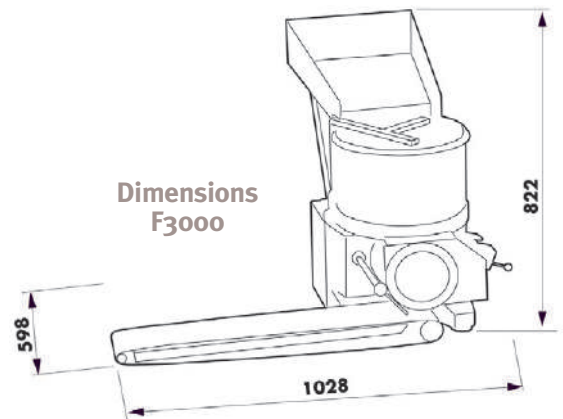

F2000 - F3000

Facile d'utilisation

Trémie contenance environ 20 Kg

Possibilité d'obtenir des portions de
formats et de poids différents

Très facile à démonter : trémie, pales,
rouleau, tapis, racleur.

Conforme aux normes C.E.

Easy use

Capacity hopper about 20 Kg

*Possibility to get any portions of
different forms and weights*

*Very easy to remove: hopper, arm,
roller, belt, scraper.*

Complies with CE norms

Options disponibles – Available Options :

Pédale de contrôle – control pedal

Interfolieur – Auto paper feeder

Tapis long – Long conveyer belt

Réhausse de trémie – Extra hopper

Empreinte spéciale – Special shapes

Empreinte double – Double shapes

Emballage export – Export packaging :

Caisse bois – Woodenbox

Réf Ref	Tension Tension	Production Production	Motor Motor	Poids net Weight
F 2000	Mono, 230 V	2000 Pièces / h	1 CV (0,75 Kw)	65 Kg
F 3000	Mono, 230 V	3000 Pièces / h	1 CV (0,75 Kw)	65 Kg